

The Cygnet Pump Range

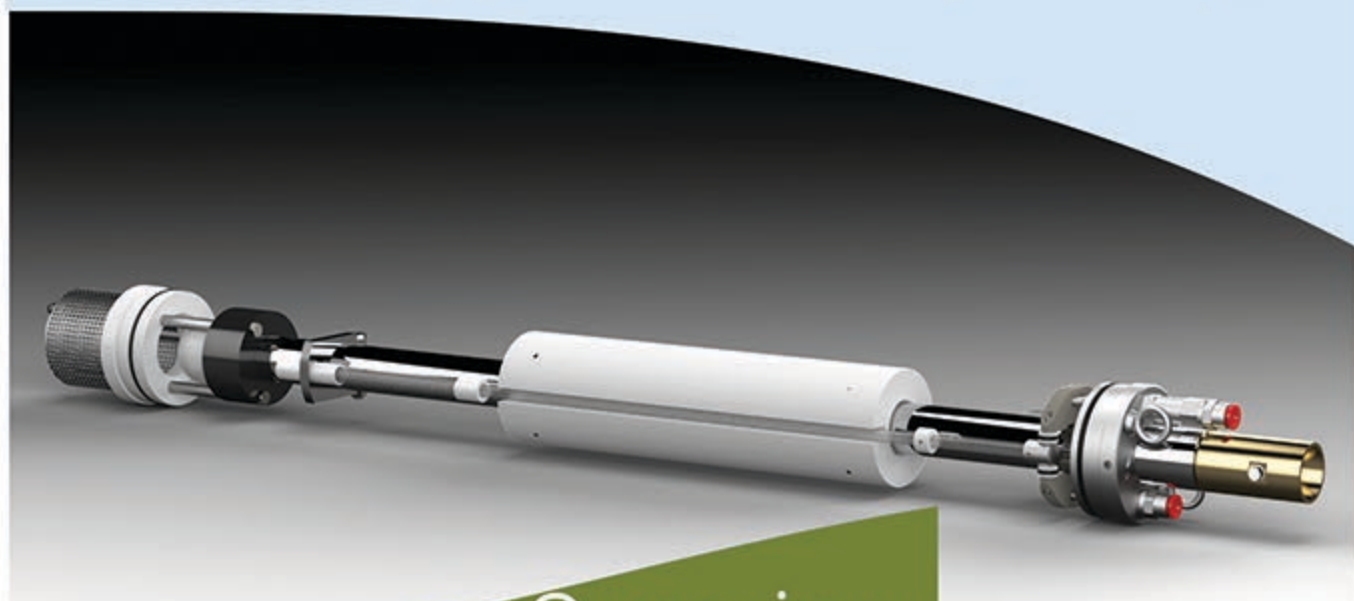

Overview

"Sentinel " pneumatic borehole pumps are market leaders in applications for leachate and condensate abstraction. Many 1000,s of Sentinels are installed on sites throughout the UK. We are also now exporting to many European countries

To compliment our existing Sentinel Standard, top-loader and short stroke models, In 2012 Cygnet developed the "Sentinel 67" . This is a slim-line model of the Sentinel and has a diameter of just 67mm. The "67" has been designed to meet demand for installation into small diameter boreholes typically gas abstraction wells

We supply supplementary fittings such as protective pump pods and inlet shrouds and offer several servicing packages for all types of pneumatic pumps Alternatively if you prefer to self service, please contact us for up to date parts price lists

